

HPF-Pre Technical Manual

Francis Deck, Mar. 15, 2012

personalpages.tds.net/~fdeck/bass

Overview

HPF-Pre is a preamp with adjustable high pass filter and phase switch for use with piezoelectric pickups on the double bass. It is intended to address the primary issues faced by bassists when playing through mainstream amps and PA systems.

Foremost, HPF-Pre is a preamp. Its high input impedance ensures proper buffering of the signal from piezo pickups. It is battery powered and housed in a tough plastic enclosure with internal shielding.

An adjustable high pass filter tunes out the subharmonic “thump” generated by the plucked bass, which otherwise can drive ported bass speakers to over-excursion. It is also a useful tool for coping with adverse acoustical environments and PA systems with excessive subwoofer support.

A phase (polarity reversal) switch is provided to help control feedback problems. It could also help when setting up systems with multiple pickups, or a pickup and a microphone.

Series 2 of the preamp adds an output volume control and an LED battery status indicator. The volume control is handy when your stage setup requires your amp to be out of arm's reach.

HPF-Pre is an "open" design. I sell the HPF-Pre at a modest price from my part-time home business. Otherwise, you are welcome to build your own.

Specifications

Here are some preliminary specifications for the HPF-Pre. This report goes into considerable detail on how these parameters are measured. The results are from initial builds that I expect to be representative.

- Input resistance / capacitance = 10 MegOhms / 220 pF
- Overall gain = +2 dB
- High pass filter corner = Adjustable from 35 to 140 Hz
- High pass filter slope = 12 dB/octave with minimal “hump”
- Phase switch = Applies phase inversion to signal
- Connectors = 1/4 inch input and output, power switched by output jack
- Distortion = 0.1% THD at 1 V p-p input
- Noise = -107 dB referred to 1 V p-p input
- Input level = Up to 4 V p-p with tolerable distortion
- Power requirement = Standard 9 V battery
- Design topology = Solid state Class-A circuit

User's guide

There isn't much to the HPF-Pre. Put in a battery. There is no reason to use an expensive battery. You should turn the volume down on your amp when flipping the phase switch, until you are certain that there won't be a loud "pop" under any conditions.

Now you hook it up. In and Out are self-explanatory. The knob adjusts the cutoff frequency. Plugging into the Output jack connects the battery. Make sure it is not a stereo plug, because the HPF-Pre uses the solid sleeve of a mono plug to connect the battery. Unplug it when you are done. As with all audio devices, it is best to turn your amp volume down while connecting or disconnecting to the HPF-Pre.



Series 2 of the preamp has a battery status indicator LED, just below the phase switch. The LED will flash briefly if the battery is OK. The indication is sufficient to provide you with at least a gig's worth of power.

For convenience, if your amp already has a high-impedance input, you can use the HPF-Pre in the effects loop of most amps.

I think that for best results, start with your amp EQ controls flat. Many electric bass amps are "voiced" meaning that they produce a non-flat response curve when the control knobs are centered. It is my opinion that a flat voicing works better for upright bass – at least as a starting point. If your amp is designed for electric bass, don't be surprised if you end up with seemingly extreme EQ settings. You are probably dialing your amp to a more flat response curve.

Start with the cutoff frequency at 35 Hz. Increase it until you are happy. If possible, find a favorable setting of the HPF-Pre before adjusting the EQ on your amp. Having the HPF-Pre doing its job liberates your EQ controls to deal with feedback. Use your ears and not your eyes. If you get good tone at a relatively high frequency setting, don't worry about what is happening to the low frequency content of your bass. It's there, but is under control.

What can I say about the phase switch? It is not a panacea, but can possibly give you a few dB of added gain before the onset of unacceptable feedback. What does it do? Perhaps "phase" is a misnomer, and "polarity" would be a better term. The sound coming from your amp is coupled into your bass, and feeds back into the pickup. The amount of feedback coupling depends on your bass and pickup, amp gain and tone settings, and acoustical surroundings.

In simplistic terms, if that coupling is additive, then you get worse feedback than if the coupling is subtractive. The phase switch lets you find the polarity that gives you less feedback.

To make it complicated, the coupling is not described by a simple phase relationship, but by frequency dependent phase shifts. The practical effect is that the phase switch can often help cope with feedback at moderate volume levels, but the amount of control is unpredictable and limited in effectiveness at high volume. For these reasons, don't expect miracles.

My experience has been that I can set the phase switch in the following way. Gradually raise your amp volume until feedback just begins to be noticeable. Now flip the phase switch. The feedback will get worse, or better. You want it to be better. Done. Now get out there and play!

Design description

Let's start with background. The HPF-Pre uses design elements that are well known, but combined in a novel way. Here are some online sources that deserve particular credit:

http://en.wikipedia.org/wiki/Butterworth_filter: Design concept for active Butterworth filter with equal resistors.

<http://www.jensen-transformers.com/as/as098.pdf>: This is the "starting point" for my active filter design, a nice 2-transistor source feedback preamp.

<http://www.ciphersbyritter.com/RADELECT/PREJFET/JFETPRE.HTM>: More information about simple discrete preamp circuits, including source feedback.

The preamp circuit is based on a classic active filter design, using discrete transistors instead of op amps. While I have nothing against op amps, the discrete design turned out to be simpler and more efficient. With half the transistors compared to op amps, current consumption is cut in half, and noise is reduced by 3 dB. Also, a Class-A design with minimal open loop gain will exhibit asymmetrical soft clipping – a musically forgiving overload response behavior that is shared with tube preamps. (Note that I am stopping short of claiming "tube sound.") Here is a schematic of the circuit.

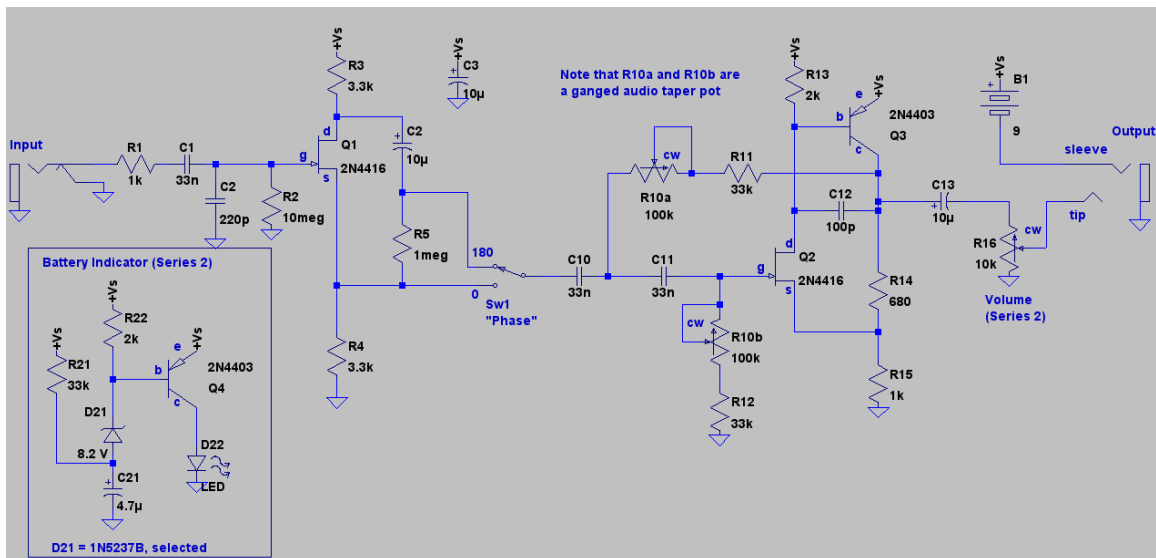

Q1 is a classic JFET phase inverter circuit. Since negligible current flows through the gate of Q1, equal currents flow through R3 and R4. The signals at the source and drain of Q1 must be of equal amplitude but opposite phase. A SPDT switch selects one of these signals – it is the phase switch. C2 and R5 hold the DC offset of these signals equal, so there is minimal "pop" when you flip the switch.

While C1 and R2 form a highpass filter, the cutoff is 0.5 Hz, not musically useful. I wanted a high value of C1 to allow for the lowest possible noise with pickups that have high capacitance. R1 limits current into Q1 if the input is temporarily overloaded, thus providing a little bit of protection.

A shunt capacitor at the front end of an audio preamp is unorthodox. However, the circuit is designed for piezo pickups. C2 provides some measure of protection for the gate of Q1, eating voltage spikes. Its low capacitance means that it has a negligible effect on the response of capacitive pickups.

The second active stage is the classic Butterworth active filter design. (Compare to the Wikipedia reference). Q2 and Q3 form a two-transistor source feedback amplifier – think of it as a crude op amp. The

gate and source of Q2 are the positive and negative inputs. R14 and R15 set the gain, and also determine the bias points of the transistors. With gain greater than unity in this stage, it is possible for the filter to have equal resistors – critical for using two stages of a dual pot. An audio taper pot is used, and it is wired "backwards" with increasing corner frequency as the knob is turned counterclockwise. This trick makes use of a widely available audio taper pot to provide a roughly linear frequency scale. The analogous op amp circuit is shown here for reference:

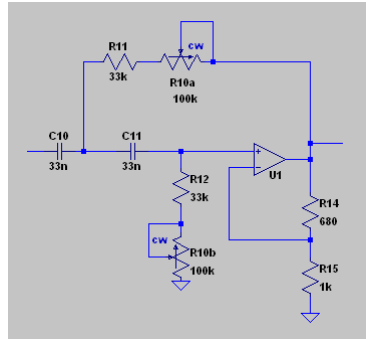

The source feedback amplifier is a clever general-purpose gain stage. The gain is set by R14 and R15. Variations on this theme abound. It is shown as a "circuit idea" in *The Art of Electronics* by Horowitz and Hill (Cambridge University Press, 1980), and of course in the preamp design on the Jensen website. Tube power amps often use an analogous cathode feedback scheme. I have used it as a low noise preamp with gains up to 20 dB, when working with a homemade magnetic pickup with unusually low sensitivity.

The negative terminal of the battery is connected to the "ring" terminal of the output jack. Inserting a mono plug into this jack grounds the ring terminal and applies power to the circuit. Guitar effects pedals have used this arrangement since the dawn of civilization. The only drawback is that you really don't want to unplug the output cable while your amp is turned on.

Series 2 of the preamp has an output volume control. This component is absent in Series 1.

The battery indicator deserves a bit of attention. A schematic is shown below. The circuit starts out with C21 discharged, so when the circuit starts out, current will flow through the D21 if the battery voltage is sufficient to overcome the Zener breakdown voltage. Drawing some of this current through the base of Q4 will cause current to flow through D22, flashing the LED. As current flows into C21, it charges up until the Zener shuts off.

Turning off the preamp allows C21 to discharge through R21, resetting it for the next time.

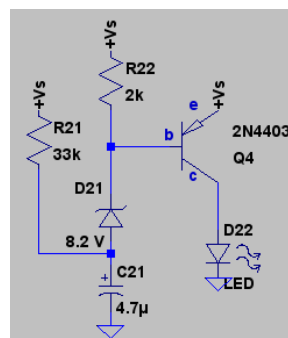

There's enough variation in Zener diodes that some of them are unsuitable. I have a test jig with a 1k resistor in series with the Zener, and measure the forward voltage of each diode. With the 1N5237B diodes, most come in around 7.8 V in my test, and I throw away the ones that are much higher than that. This appears to result in a "flash" threshold of around 8.5 V, which seems like a decent level. Since 9-V alkaline

batteries start out around 9.5 V, you get a reasonable lifetime with a 1-V drop. My hope is that if you see a “flash,” it means that you have enough juice for one more gig.

Test results

Frequency response: I used my FreeSA spectrum analyzer program to measure response curves at three positions of the frequency knob. (Note that this program is obsolete due to “progress” in Microsoft Windows, but the free program Visual Analyzer works nicely). The result shows that I nailed the Butterworth response function pretty well.

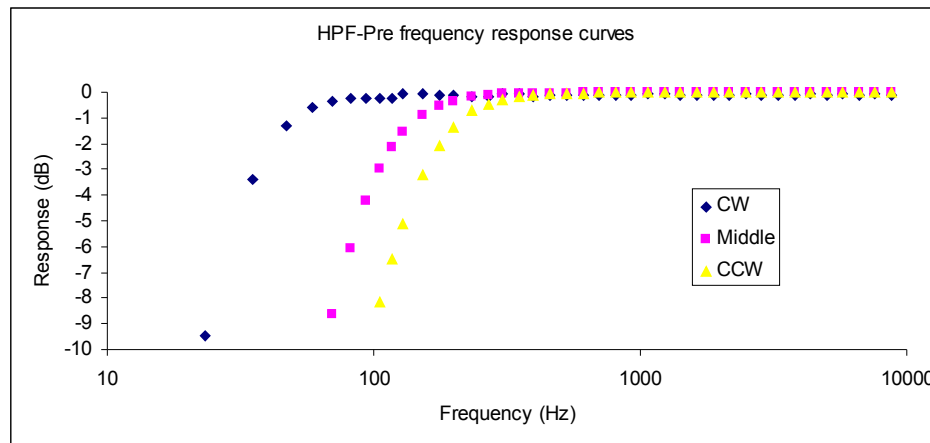

Noise: By necessity, my noise measurement process is a bit convoluted, as I am not using commercial calibrated measurement gear. The first edition of *The Art of Electronics* by Horowitz and Hill suggests comparing the noise from a grounded input, and from a calibrated noise source. My noise source is a 100 k Ω resistor, which generates thermal noise at a level of 40 nV/ $\sqrt{\text{Hz}}$ at room temperature, or 5.7 μV RMS over a 20 kHz bandwidth. My setup is:

Resistor \rightarrow HPF Preamp \rightarrow Another Preamp \rightarrow PC sound card input

I used my own FFT spectrum analyzer program to collect spectra of the resistor, the grounded input of the preamp, and the grounded input of “another preamp,” which boosts the signal above the noise floor of my PC sound card. Subtracting the first two measurements (using quadrature subtraction, meaning the square root of the difference of the squares) gave me a reference that corresponds to 40 nV/ $\sqrt{\text{Hz}}$. Subtracting the second two measurements in the same way gave me the noise level of the HPF-Pre. Scaling this noise level to the 40 nV/ $\sqrt{\text{Hz}}$ reference resulted in a measured input noise for the HPF-Pre of 9 nV/ $\sqrt{\text{Hz}}$. Over 20 kHz bandwidth and flat weighting, this is a noise level of -107 dB referred to 1 V p-p. Some premium JFET op amps have lower noise, but draw much more current.

Distortion: My test setup looks like:

PC sound card \rightarrow Buffer with gain, voltmeter at output \rightarrow HPF preamp \rightarrow PC sound card

First, I took the HPF preamp out of the system, to check the inherent distortion of my measurement system. I used my own software, and simulated distortion waveforms by adding a small amount of the second harmonic. Here are the results:

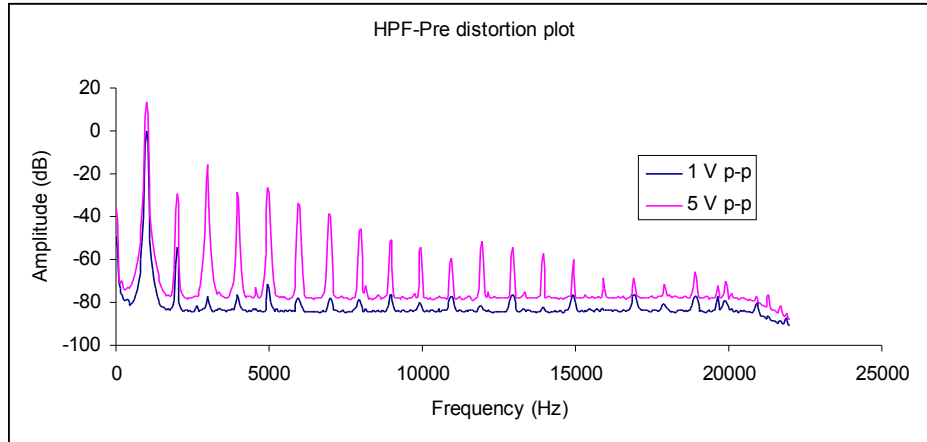

At 1 V p-p, The second harmonic is at ≈ -55 dB, and the third harmonic at ≈ -78 dB. The rest of the harmonics are consistent with the distortion floor of my measurement system. Pure second harmonic distortion at -55 dB corresponds to a THD of 0.17%, which is quite respectable for a Class-A circuit. This is with an input voltage of 1 V p-p.

At a higher input voltage, you see a slew of harmonics. That's serious distortion.

To estimate the dynamic range of the filter, I measured the total harmonic distortion at different input voltage levels using Virtual Analyzer. Here is the plot:

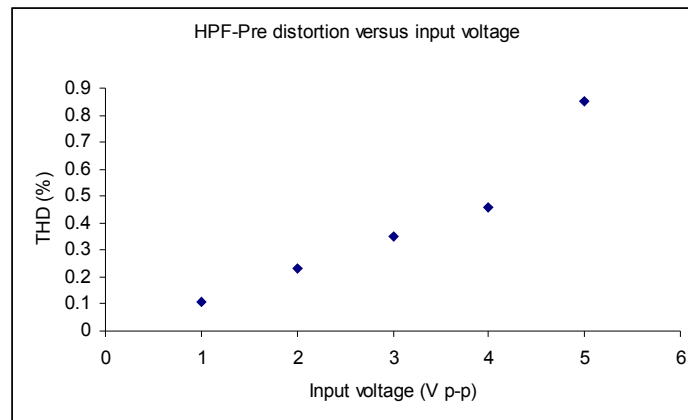

Distortion rises with increasing amplitude. But unlike an op amp circuit, the dynamic range is not a hard upper limit. You can push beyond this range, at least on the transient at the front end of a plucked note, with minimal audible effect. I expect this circuit to be quite forgiving.

HPF Sales Information

At present, my intention is to offer the HPF-Pre to bassists in the United States, as the device does not carry the CE marking. Price is US \$50 per unit for Series 1, or \$65 for Series 2, plus \$5 handling per order, FOB Madison Wisconsin. Payment is via PayPal using my merchant account:

francisdeck@tds.net

When ordering via PayPal, don't forget to indicate your name and address. Shipping is via good old US Post Office.

Acknowledgement

I am indebted to **drurb** from the TalkBass forum, for trying my first prototype, for many valuable comments and suggestions, and for prodding me to put the preamp on the market.